



# SJIII 3220/26

## ELECTRIC SCISSOR LIFTS

### STANDARD FEATURES

- Drivable at full height
- Variable speed, rear two wheel hydraulic drive
- Dual holding brakes
- Proportional controls for drive & lift functions
- 3' (0.91 m) Roll out extension deck
- 24V DC power source
- Low voltage battery protection
- Up to 30% Gradeability
- Solid rubber, non-marking tires
- Pothole protection system
- 110V AC outlet on platform with GFI
- 28 mph wind rating (12.5 m/s)
- Tilt alarm with drive & lift cut-out
- All motion audible alarm
- Lanyard attachment points
- Operator horn
- Hinged railing system (3226)
- Forklift pockets and tie down/lift lugs
- Relay based control system
- Color coded and numbered wiring system
- Telematics ready

### ACCESSORIES AND OPTIONS

- Flashing light
- Dual flashing lights
- Extended control box cable
- Pipe rack (3220)
- Drywall carrier (3226)
- 6' (1.8 m) Powered ext. deck (3220)\*
- 800W AC inverter
- 250 Ah batteries (cannot be combined with EE rating package)
- AGM Batteries
- EE rating package
- DC motor controller
- Hinged railing system (3220)
- Half height spring hinged gate
- Full height spring hinged gate\*
- Non destructive testing
- Warranty Options (3 year or 5 year plans available)

\* Not available with hinged railing system.

† Capacities, and machine weights may differ when options are added.

# SJIII 3220/26 ELECTRIC SCISSOR LIFTS

Dimensions	SJIII 3220	SJIII 3226
<b>A</b> Work Height	26' (7.92 m)	32' (9.75 m)
<b>B</b> Raised Platform Height	20' (6.10 m)	26' (7.92 m)
<b>C</b> Lowered Platform Height	38" (0.97 m)	45" (1.14 m)
<b>D</b> Overall Width	32" (0.81 m)	32" (0.81 m)
<b>E</b> Overall Length	91.5" (2.32 m)	91.5" (2.32 m)
<b>F</b> Stowed Height (Rails Up)	77.5" (1.97 m)	84.7" (2.15 m)
<b>G</b> Stowed Height (Rails Down)	OPT 63.5" (1.61 m)	70.6" (1.79 m)
<b>H</b> Platform Width (Inside Dimension)	28" (0.71 m)	28" (0.71 m)
<b>I</b> Platform Length (Inside Dimension)	84" (2.13 m)	84" (2.13 m)
Specifications	SJIII 3220	SJIII 3226
Extension Deck (Roll Out)	3' (0.91 m)	3' (0.91 m)
Ground Clearance (Stowed)	3.5" (8.89 cm)	3.5" (8.89 cm)
Ground Clearance (Raised)	0.75" (1.90 cm)	0.75" (1.90 cm)
Wheelbase	69" (1.75 m)	69" (1.75 m)
Weight	3,510 lbs (1,592 kg)	4,135 lbs (1,876 kg)
Gradeability	30%	30%
Turning Radius (Inside)	50" (1.27 m)	50" (1.27 m)
Turning Radius (Outside)	108" (2.74 m)	108" (2.74 m)
Lift Time (With Rated Load)	33 sec	56 sec
Lower time (With Rated Load)	29 sec	42 sec
Drive Speed (Stowed)	2 mph (3.2 km/h)	2.4 mph (3.9 km/h)
Drive Speed (Raised)	0.7 mph (1.1 km/h)	0.7 mph (1.1 km/h)
Maximum Drive Height	Full Height	Full Height
Capacity (Overall)	900 lbs (408 kg)	500 lbs (227 kg)
Distributed Capacity (Main Platform)	600 lbs (159 kg)	250 lbs (113 kg)
Distributed Capacity (Extension Deck)	300 lbs (136 kg)	250 lbs (113 kg)
Local Floor Load (With Rated Load)	130 psi (897 kPa)	130 psi (897 kPa)
Overall Floor Load (With Rated Load)	245 psf (12 kPa)	235 psf (12 kPa)
Maximum # of Persons	2	2
Wind Rating	28 mph (12.5 m/s)	28 mph (12.5 m/s)
Tire Type	Solid, N/M	Solid, N/M
Tire Size	16 x 5 x 12	16 x 5 x 12

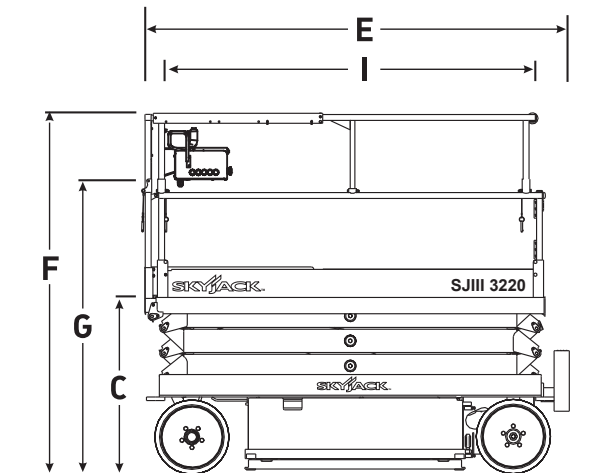
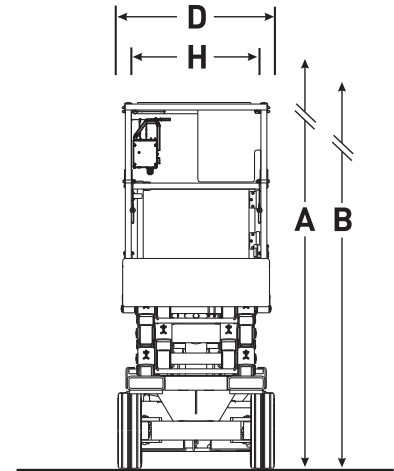

**Skyjack Head Office**  
 55 Campbell Rd. Guelph, ON Canada N1H 1B9  
 Sales Inquiries: 1-877-755-4387 (1-877-SJLIFTS)  
 Main Switchboard: 1-800-265-2738  
 Phone: 519-837-0888  
 Fax: 519-837-8104  
 Email: skyjack@skyjack.com  
 www.skyjack.com

This brochure is for illustrative purpose only and based on the latest information at the time of printing. Skyjack Inc. reserves the right to make changes at any time, without notice, to specifications, standard and optional equipment. Consult the Operating Maintenance and Parts Manuals for proper procedures. Work platforms have been tested to comply with ANSI and CSA standards as interpreted by Skyjack Inc.

